

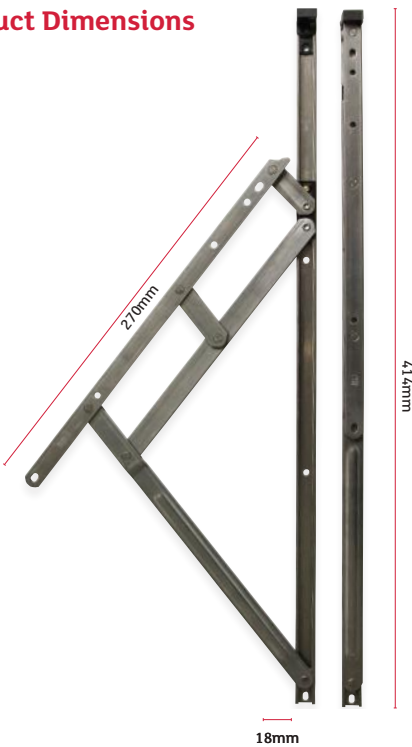

ALL QUANTUM PRODUCTS HAVE
THE TOTAL HARDWARE
10 YEAR GUARANTEE

Quantum Heavy Duty Friction Stays

Product Dimensions



Designed for commercial applications, the Quantum Heavy Duty Friction Stays are suitable for all materials, from uPVC, to timber and aluminium.

They are available in top and side hung versions, and come in a choice of sizes. Tested to 50,000 cycles, these heavy duty friction stays are made to last, and will ensure the smooth operation of large casement windows.

Features and Specifications:

- Available in side hung variants of 12" and 16" with the capability of holding up to 33kg
- Available in top hung variants of 16", 20" and 24" with the capability of holding up to 43kg
- Available in 14mm and 17mm stack heights
- Manufactured from stainless steel
- Tested to 50,000 cycles
- Easy to fit
- Smooth operation
- Superior weather and draught proofing
- 10 year mechanical guarantee



For more information call
0113 243 2255 or visit
www.totalhardwareltd.co.uk

Unit B1 Latchmore Park, Latchmore Road, Beeston, Leeds, W Yorkshire LS12 6DN
f totalhardwareltd @Totalhardware

